

OV

Ø 18 ÷ 80 mm - Oval Cylinders

Compact oval cylinder with adjustable pneumatic cushioning and standard magnetic piston its special shape allows the assembly of several coupled cylinders with reduced overall dimensions (in width) and offers a reduction of overall dimensions compared to traditional ISO cylinders.

Available ATEX version upon request

CE Ex II 2Gc IIC T5 II 2Dc T100°C



TECHNICAL CHARACTERISTICS

Ambient temperature	-20 ÷ 80 °C
Fluid	filtered air with or not lubrication
Working pressure	1,5 ÷ 10 bar
Bore	Ø18 - 25 - 32 - 40 - 50 - 63 - 80 mm
Cushionings	adjustable pneumatic in both sides

CONSTRUCTIVE CHARACTERISTICS

End-caps	anodized aluminium
Barrel	anodized aluminium
Piston	aluminium
Guide slide	Turcite (Ø18 - 25 - 32 - 63 - 80), Acetalic resin (Ø40 - 50)
Piston rod	stainless steel (Ø18 - 25), chromium-plated steel (Ø32 - 80)
Piston seals	nitrile rubber self-lubricating
Guide bush for piston rod	steel structure, PTFE and sintered bronze sliding
Rod seal	polyurethane
Magnet	Neodymium

CODIFICATION KEY

O	V	2	0	0	0	3	2	0	0	5	0	
1	2	3	4	5	6							

1 Series

OV = Ø18 ÷ 80 mm
Oval cylinders

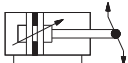

2 Type

- 1 = Stainless steel female piston rod (Ø18÷80)
- 2 = Chromium-plated steel female piston rod (Ø32÷80)
- 3 = Stainless steel male piston rod (Ø18÷80)
- 4 = Chromium-plated steel male piston rod (Ø32÷80)

3 Version

- 00 = D.A. Standard version
- 01 = D.A. Through piston rod
- 02 = D.A. Hollow through piston rod

D.A. = Double-acting

4 Bore (mm)

018 = Ø18 050 = Ø50
025 = Ø25 063 = Ø63
032 = Ø32 080 = Ø80
040 = Ø40

5 Stroke (mm)

0010 - 0025 - 0040 - 0050 - 0080 - 0100 - 0125
0160 - 0200 (Ø18-25)

0010 - 0025 - 0040 - 0050 - 0080 - 0100 - 0125
0160 - 0200 - 0250 - 0320 (Ø32÷80)

6 ATEX option

X = ATEX (upon request)

For types and versions, see ATEX catalogue

Comparison of A dimension: OV cylinder vs ISO standard cylinder

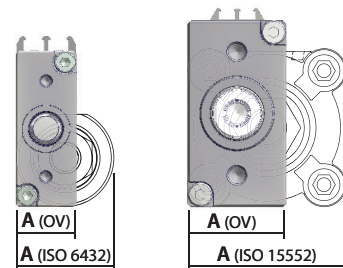

Ø	A (OV)	A (ISO)	Reduction
18	16	28	-42%
25	20	31	-35%
32	24,5	48	-50%
40	38	54	-30%
50	40	67	-40%
63	50	78	-35%
80	60	97	-38%

Nominal tolerances on the stroke

Ø	Nominal tolerances
	mm
18	+ 1,5/0
25	+ 1,5/0
32	+ 2/0
40	+ 2/0
50	+ 2/0
63	+ 2,5/0
80	+ 2,5/0

Maximum applicable torque (Nm) and related max. rotation (°)

Ø	Max applicable torque	Related Max rotation
	(Nm)	
18	0,80	0,90°
25	1,00	0,80°
32	1,40	0,60°
40	1,70	0,40°
50	2,00	0,35°
63	2,30	0,30°
80	2,60	0,30°

Theoretical forces (N) at different working pressure (bar)

Ø	Surface area		Working pressure					Working pressure				
	mm ²		bar					bar				
	Thrust	Traction	Thrust					Traction				
			2	4	6	8	10	2	4	6	8	10
18	255	205	54	108	162	216	270	41	82	122	163	204
25	491	412	98	196	295	393	491	82	165	247	330	412
32	804	691	161	322	483	643	804	138	276	415	553	691
40	1256	1056	251	502	754	1005	1256	221	442	663	884	1105
50	1962	1649	393	785	1178	1570	1963	330	660	990	1320	1650
63	3116	2802	623	1246	1870	2493	3116	560	1120	1682	2240	2800
80	5024	4710	1005	2010	3015	4019	5024	942	1884	2826	3770	4711

Cushion

Ø	Length
	mm
18	8
25	10
32	10
40	14
50	Front 11/Rear 14
63	Front 11/Rear 14
80	Front 20/Rear 27

1

Mass - Double-acting cylinders

Ø	Cylinders - stroke 0	Increase per mm stroke	Moving element - stroke 0	Increase per mm stroke
	g	g	g	g
18	120	1,3	30	0,4
25	180	1,8	60	0,6
32	290	2,4	105	0,9
40	465	3,4	165	1,6
50	780	4,7	230	2,5
63	1145	5,8	295	2,5
80	2245	8,6	535	2,5

Mass - Double-acting cylinders with through piston rod

Ø	Cylinders - stroke 0	Increase per mm stroke	Moving element - stroke 0	Increase per mm stroke
	g	g	g	g
18	140	1,7	50	0,8
25	210	2,4	90	1,2
32	330	3,2	140	1,8
40	535	5	235	3,2
50	900	7,2	350	5
63	1265	8,3	415	5
80	2390	11	680	5

Fixing elements and accessories

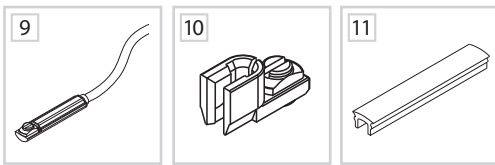
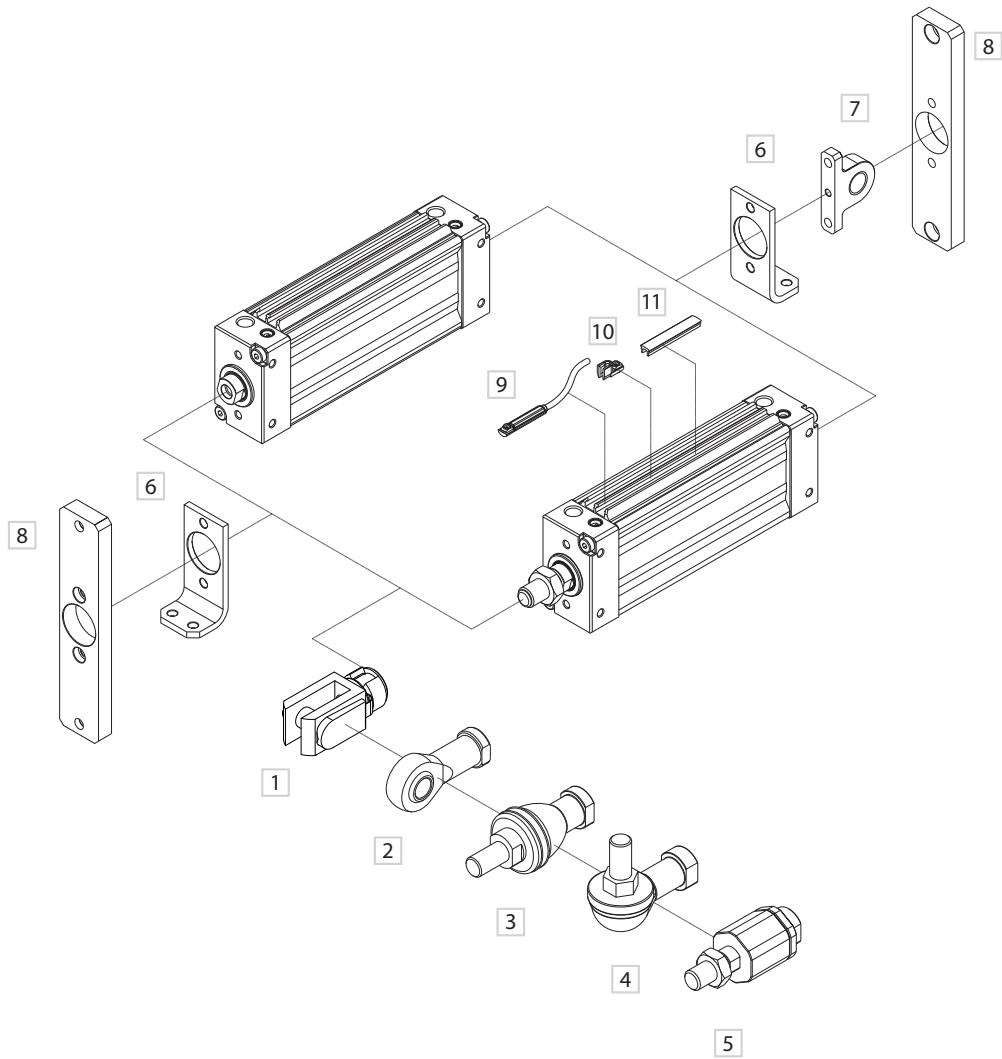

DESCRIPTION	NOTE	PART NO.
1 Female fork with clips		KF-15___ / MF-15___ (Ø18)
2 Articulated self-lubricating fork		KF-17___ / MF-17___ (Ø18)
3 Fork with axially mounted articulated pin		KF-22___ / MF-22___ (Ø18)
4 Fork with angle mounted articulated pin		KF-23___ / MF-23___ (Ø18)
5 Floating joint		KF-24___
6 Angle bracket		OVF-13___
7 Male hinge		OVF-11___
8 Flange		OVF-12___
9 DF sensor		DF-___
10 Cable clamping for DF sensor		DF-001
11 DHF covering strip		DHF-0020100

Double acting Ø 18 mm

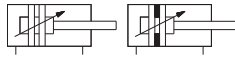
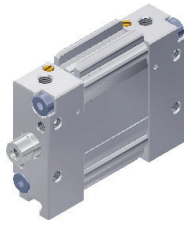

> Female/male rod

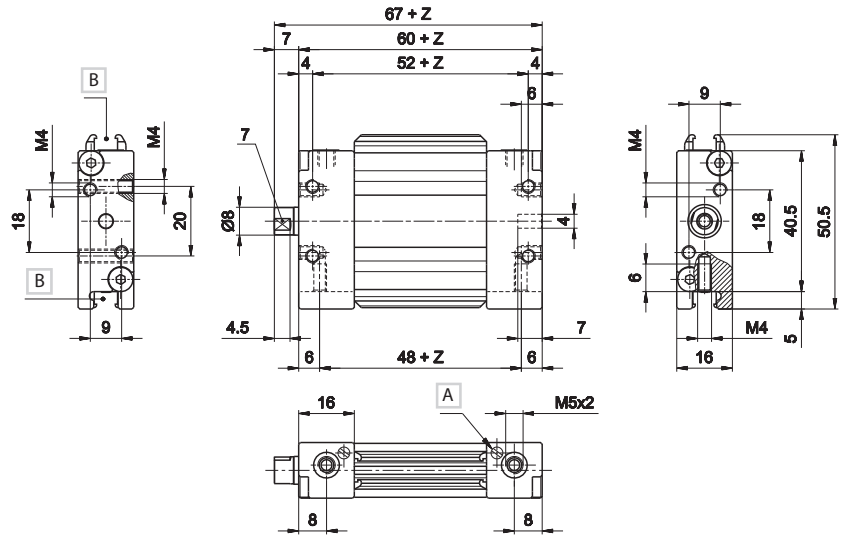
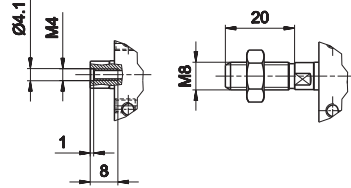

Double acting Ø 25 ÷ 80 mm

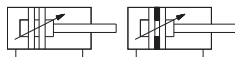

> Female/male rod

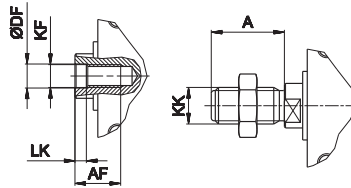

> Version Ø 80 mm

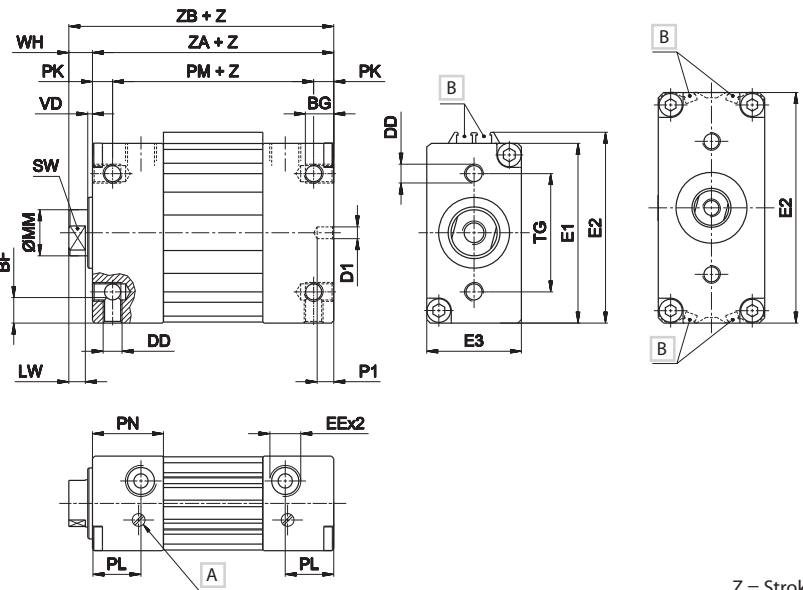

Z = Stroke

Ø	A	AF	BF	BG	DD	DF	D1	EE	E1	E2	E3	KF	KK	
			min.	min.			H 9							
25	22	12	8	8	M4	5,1	4	M5	52	57	20	M5	M10x1,25	
32	22	14	8	8	M5	6,2	4	G1/8	61	66	24,5	M6	M10x1,25	
40	24	16	10	12	M5	8,2	4	G1/8	61,5	67	38	M8	M12x1,25	
50	32	20	12	14	M8	10,5	5	G1/4	76	81	40	M10	M16x1,5	
63	32	20	14	10,5	M10	10,5	5	G1/4	92	97	50	M10	M16x1,5	
80	32	20	15	15	M10	10,5	5	G1/4	-	130	60	M10	M16x1,5	
Ø	LK	LW	MM	PK	PL	PM	PN	P1	SW	TG	VD	WH	ZA	ZB
25	2	4,5	10	4	12	54	16	7	8	32	2	8	62	70
32	2,5	5	12	5	7,5	62	18	7	10	36	2	8	72	80
40	3	6	16	7,5	14,5	61	22	7	13	40	2	9	76	85
50	5	7	20	8,5	20,5	65	30	7	17	50	2	10	82	92
63	5	7	20	8,5	20,5	65	30	7	17	60	2	10	82	92
80	5	7	20	9	20	88	30	7	17	75	2	12	106	118

- A Pneumatic cushioning adjusting screw
- B Sensor groove

Double acting through piston rod Ø 18 mm

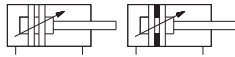
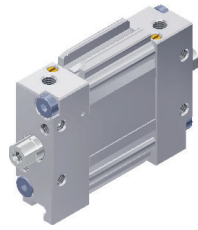

> Female/male rod

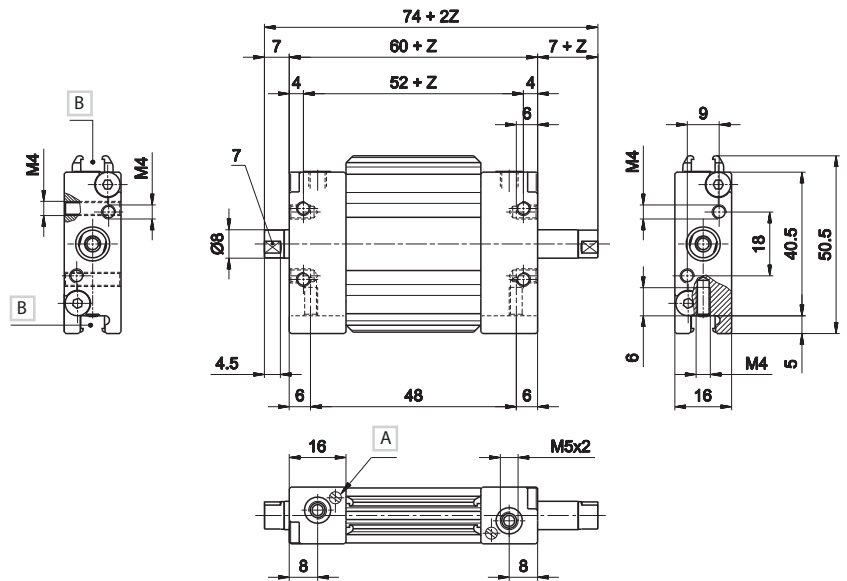
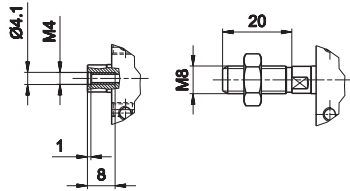

Double acting through piston rod Ø 25 ÷ 80 mm

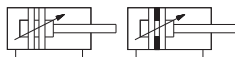
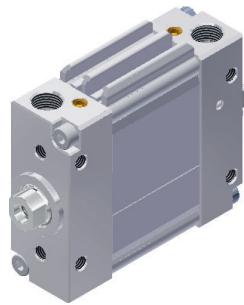

> Female/male rod

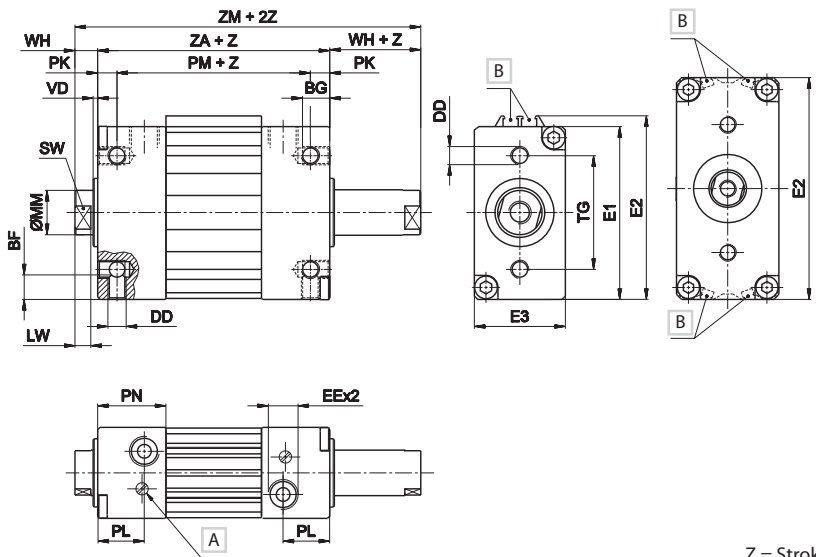
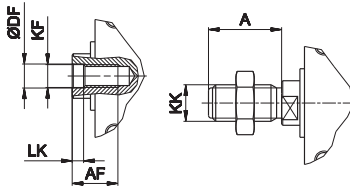

> Variant Ø 80 mm

Z = Stroke

Ø	A	AF	BF min.	BG min.	DD	DF	EE	E1	E2	E3	KF	KK
25	22	12	8	8	M4	5,1	M5	52	57	20	M5	M10x1,25
32	22	14	8	8	M5	6,2	G1/8	61	66	24,5	M6	M10x1,25
40	24	16	10	12	M5	8,2	G1/8	61,5	67	38	M8	M12x1,25
50	32	20	12	14	M8	10,5	G1/4	76	81	40	M10	M16x1,5
63	32	20	14	10,5	M10	10,5	G1/4	92	97	50	M10	M16x1,5
80	32	20	15	15	M10	10,5	G1/4	-	130	60	M10	M16x1,5

Ø	LK	LW	MM	PK	PL	PM	PN	SW	TG	VD	WH	ZA	ZM
25	2	4,5	10	4	12	54	16	8	32	2	8	62	78
32	2,5	5	12	5	7,5	62	18	10	36	2	8	72	88
40	3	6	16	7,5	14,5	61	22	13	40	2	9	76	94
50	5	7	20	8,5	20,5	65	30	17	50	2	10	82	102
63	5	7	20	8,5	20,5	65	30	17	60	2	10	82	102
80	5	7	20	9	20	88	30	17	75	2	12	106	130

- A Pneumatic cushioning adjusting screw
- B Sensor groove

Double acting female/male hollow through piston rod Ø 18 mm

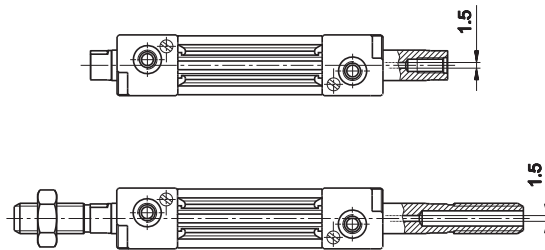
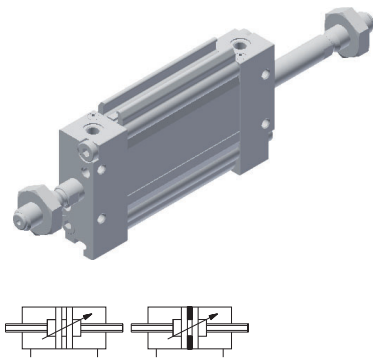

Double acting female/male hollow through piston rod Ø 25 ÷ 80 mm

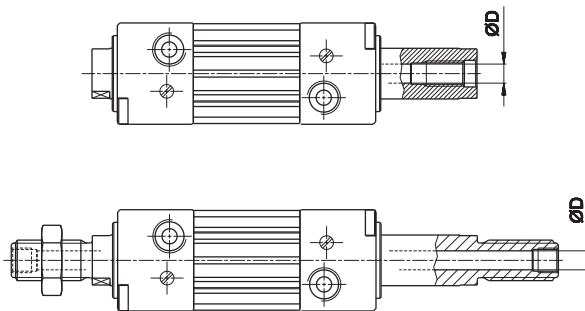
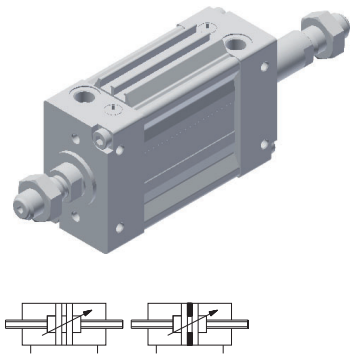

Ø	D
25	2,5
32	3,5
40	5
50	7,5
63	7,5
80	7,5

Ø18 ÷ 25 Max stroke **100 mm** Ø32 ÷ 80 Max stroke **160 mm**

For all other dimensions please refer to the through piston rod version at previous page.

For other types of cylinders kindly contact our sales office.

1

Male hinge

Ø 18 mm

Ø 25 ÷ 80 mm

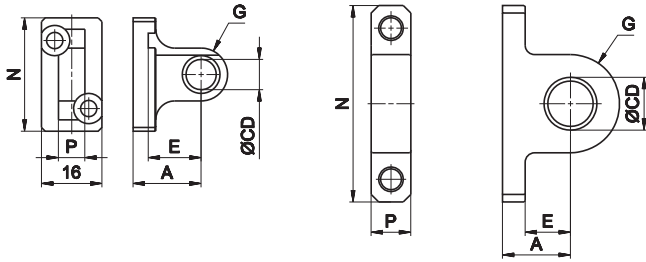

Ø	A	CD	E	G	N	P	Part No.
	ØH7					H12	
18	18	8	14	7	30	7	OVF-11018
25	14	8	8	7,5	42	9	OVF-11025
32	15	10	9	10	47	10,5	OVF-11032
40	18	12	12	13	52	10,5	OVF-11040
50	20	12	12	13	68	20	OVF-11050
63	24	16	16	17	80	25	OVF-11063
80	24	16	9	17	95	25	OVF-11080

Material: Aluminium

Flange

Ø 18 mm

Ø 25 ÷ 40 mm

Ø 50 ÷ 80 mm

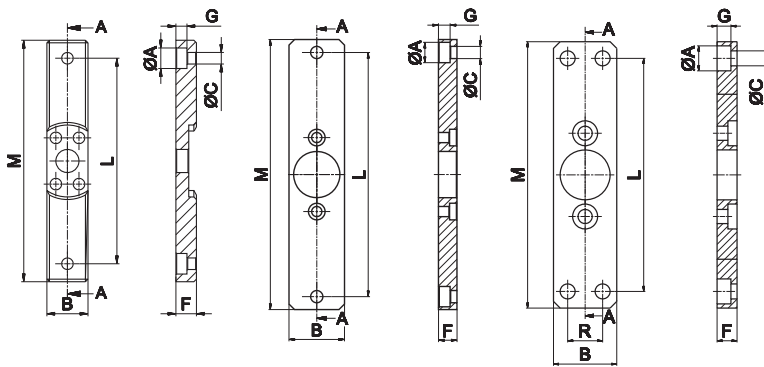

Ø	ØA	B	ØC	F	G	L	M	R	Part No.
	18	8	16	4,5	8	4,3	80	94	
25	10	20	5,5	10	5,7	100	115	-	OVF-12025
32	11	24	6,6	10	6,3	115	130	-	OVF-12032
40	11	30	6,6	10	6,3	132	146	-	OVF-12040
50	15	38	9	12	8,3	140	160	21	OVF-12050
63	15	50	9	15	8,3	140	160	33	OVF-12063
80	15	60	9	20	8,3	178	200	40	OVF-12080

Material: Aluminium

Angle bracket

Ø 18 mm

Ø 25 mm

Ø 32 ÷ 80 mm

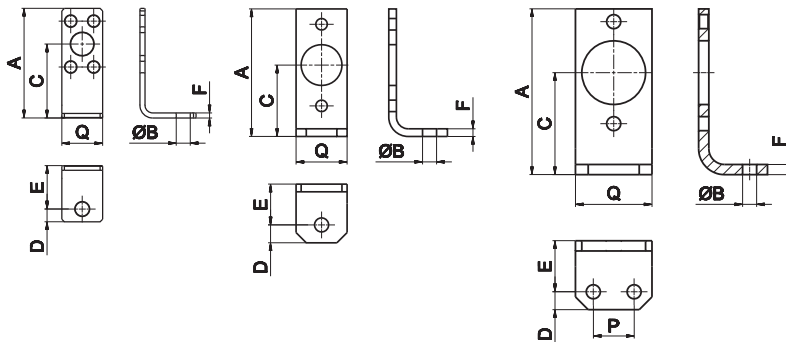

Ø	A	ØB	C	D	E	F	P	Q	Part No.
	18	43	5,5	29	5	17	2	-	
25	50	5,5	28	7	16	3	-	20	OVF-13025
32	55	5,5	32	5,5	18	3	13	24	OVF-13032
40	65	5,5	40	7	20	4	16	30	OVF-13040
50	85	6,6	50	8	24	4	22	38	OVF-13050
63	105	9	63	10	27	4	30	50	OVF-13063
80	130	9	80	10	29	6	40	60	OVF-13080

Material: Zinc-plated steel

Female fork with clips

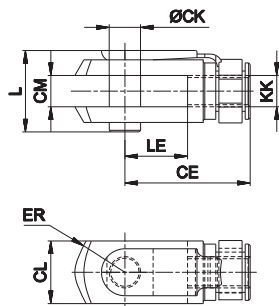
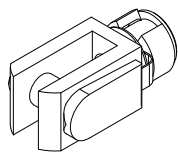

Material: Zinc-plated steel

Cylinder Ø	CE	CK	CL	CM	ER	KK	L	LE	Mass g	Part no.
18	32	8	16	8	10	M8x1,25	22	16	46	MF-15020
25-32	40	10	20	10	16	M10x1,25	26	20	90	KF-15032
40	48	12	24	12	19	M12x1,25	32	24	150	KF-15040
50-63-80	64	16	32	16	25	M16x1,5	40	32	340	KF-15050

Articulated self-lubricating fork

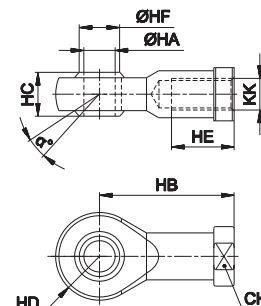
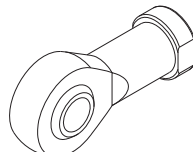

Material: Zinc-plated steel

Cylinder Ø	α°	CH	KK	HA	HB	HC	HD	HE	HF	Mass g	Part no.	
18	14	14	M8x1,25	H7	8	36	12	12	16	10,4	46	MF-17020
25-32	13	17	M10x1,25	10	43	14	14	20	12,9	76	KF-17032	
40	13	19	M12x1,25	12	50	16	16	22	15,4	110	KF-17040	
50-63-80	15	22	M16x1,5	16	64	21	21	28	19,3	220	KF-17050	

Fork with axially mounted articulated pin

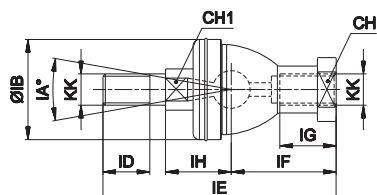
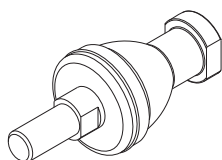

Material: Zinc-plated steel

Cylinder Ø	CH	CH1	IA°	KK	IH	IB	ID	IE	IF	IG	Mass g	Part no.
18	14	10	30	M8x1,25	16	28	12	65	32	16	75	MF-22020
25-32	17	11	30	M10x1,25	19,5	32	15	74,5	35	18	120	KF-22025
40	19	17	30	M12x1,25	22	36	17	84	40	20	185	KF-22040
50-63-80	22	19	22	M16x1,5	27,5	47	23	112	50	27	360	KF-22050

Fork with angle mounted articulated pin

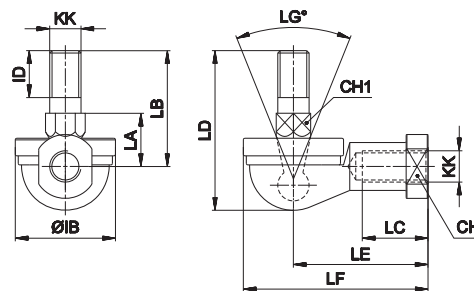
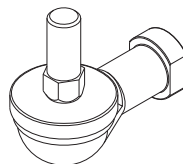

Material: Zinc-plated steel

Cylinder Ø	CH	CH1	LG°	KK	IB	ID	LA	LB	LC	LD	LE	LF	Mass g	Part no.
18	14	10	50	M8x1,25	28	12	14	31	17	42,5	36	48	67	MF-23020
25-32	17	11	50	M10x1,25	32	15	17	37	21	50,5	43	57	110	KF-23025
40	19	17	50	M12x1,25	36	17	19	42	27	57,5	50	66	165	KF-23040
50-63-80	22	19	40	M16x1,5	47	23	23,5	60	33	79,5	64	84	330	KF-23050

Floating joint

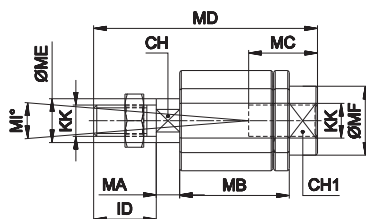
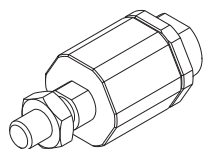

Material: Zinc-plated steel

Cylinder Ø	CH	CH1	ID	KK	MA	MB	MC	MD	ME	MF	MG	MH	MI°	Mass g	Part no.
18	7	11	11	M8x1,25	5	26	16	57	8	12,5	17	19	8	60	MF-24020
25-32	12	19	71	M10x1,25	5	35	20	71	14	22	30	32	8	220	KF-24032
40	12	19	75	M12x1,25	5	35	20	75	14	22	30	32	8	230	KF-24040
50-63-80	20	30	103	M16x1,5	8	54	32	103	22	32	41	45	6	660	KF-24050

Piston rod locknut (zinc-plated steel)

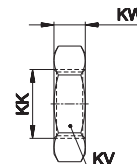

Material: Zinc-plated steel

Cylinder Ø	KK	KV	KW	Mass g	Part no.
18	M8	13	5	3,4	KF-16020
25-32	M10x1,25	17	6	5	KF-16032
40	M12x1,25	19	7	10	KF-16040
50-63-80	M16x1,5	24	8	20	KF-16050